



S4 Turbo



Heating with Firewood

From a renowned company

Right from the beginning, Froling has specialised in the efficient use of wood as an energy source. Today the Froling name stands for modern biomass heating technology. Our firewood, wood chip and pellet boilers are used successfully across Europe. All products are produced at our own factories in Austria and Germany. Our state of the art machinery guarantees quality down to the smallest detail. The excellent coverage of Froling's service network ensures customers' needs are handled quickly and reliably.



Innovation and competence

Froling has been working with **environmentally friendly, CO₂-neutral heat from wood** for almost 5 decades. Much of the currently accepted technology originated with us. Our experienced engineers have set themselves high targets for the S4 Turbo firewood boiler, and they have implemented them:

- Optimal combustion for emissions and efficiency
- Robust combustion chamber with long service life
- Expanded automatic functions (e.g. automatic heat up)
- User-friendly cleaning and ash removal
- Modular control technology with bus system



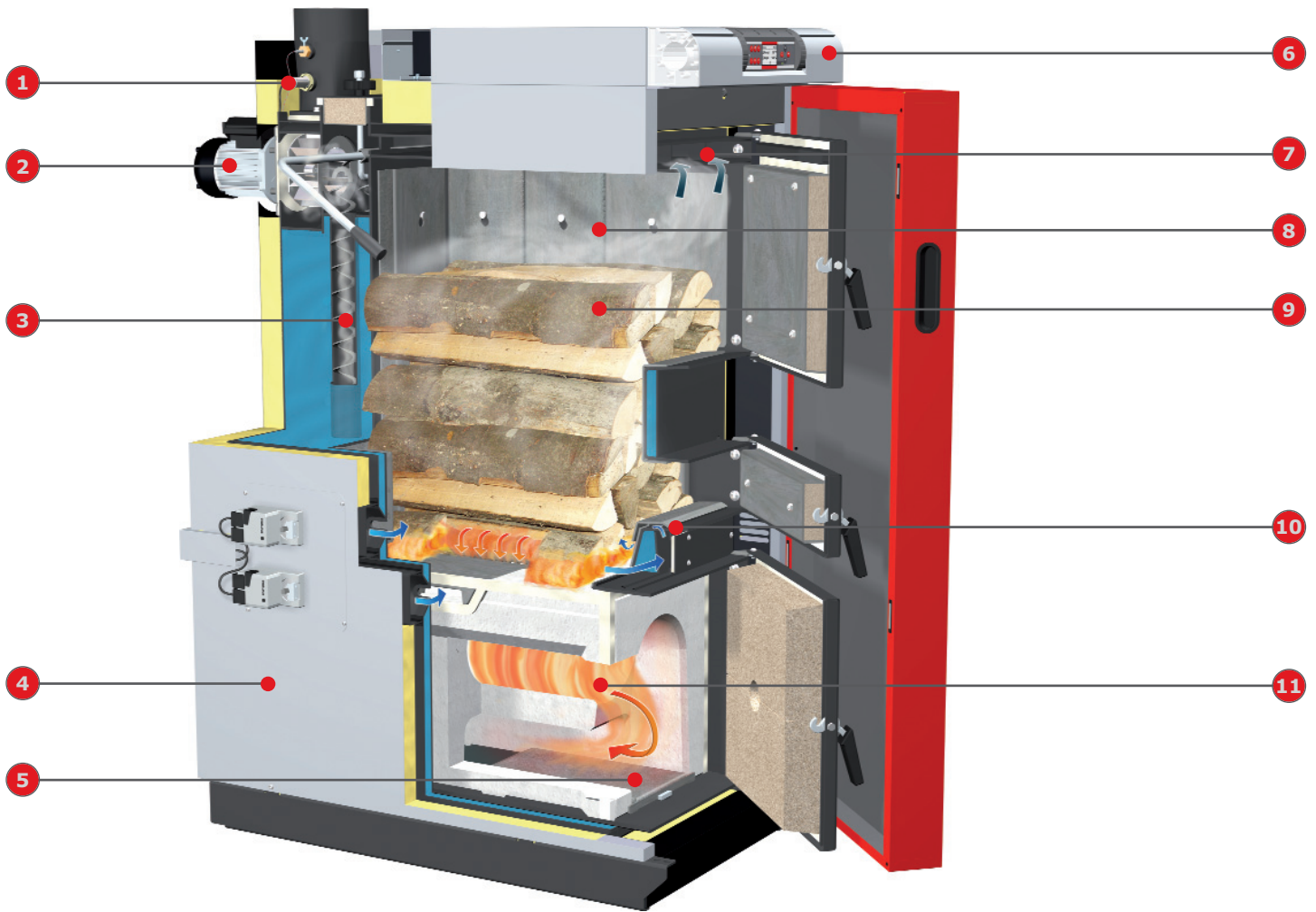

The firewood boiler with special benefits:

- 1 Lambda probe for optimal combustion.
- 2 Speed-regulated induced draught fan for maximum ease of use.
- 3 Serial WOS system (efficiency optimising system) for high efficiency and user-friendly cleaning from outside.
- 4 Top quality heat insulation.
- 5 Generous cleaning openings for easy cleaning from the front.
- 6 New bus control design with Lambdatronic S 3200 micro-processor control.
- 7 Carbonisation gas extraction system for "smoke-free" reloading.
- 8 Hot cladding for efficient combustion without a build-up of tar.
- 9 Large fuel loading chamber for pieces of wood up to half a metre in length enables long reloading intervals.
- 10 Automatic heat up with special air ducts for fast heat up (optional: automatic ignition device).
- 11 New combustion chamber shape for the lowest emissions through a long combustion zone.

The Next Generation



Feature: Expanded fuel loading chamber for half metre pieces of wood with hot cladding

- Benefits:
- Easy loading
 - Long combustion time
 - Long reloading intervals

Even the 15 kW models of the S4 Turbo can burn half metre pieces of wood. As a result of the large loading area, long loading intervals are possible and front loading becomes easy. Often the boiler only has to be filled once for the whole day. While the S4 Turbo is providing pleasant warmth from wood, you have more time for other things.

Feature: New combustion chamber shape

- Benefits:
- Very long combustion zone
 - Reduced emissions
 - Far more environmentally friendly

Froling has developed the traditional cylindrical combustion chamber shape and is setting new standards with an optimised heating gas duct. The lengthened combustion zone further reduces emissions, due to this you contribute considerably to cleaner air by using this firewood boiler. The robust construction and the use of silicon carbide as a material for the high temperature combustion chamber enable a longer service life.

Feature: Serial WOS system

- Benefits:
- High efficiency
 - Easy cleaning from outside
 - Low energy consumption

We never compromise on ease of use. The WOS (Efficiency Optimisation System) integrated in the S4 Turbo as standard, consists of special turbulators, which are placed in the heat exchanger pipes. The lever mechanism makes it easy to clean the heating surfaces from outside. Another benefit is that clean heating surfaces lower energy consumption.

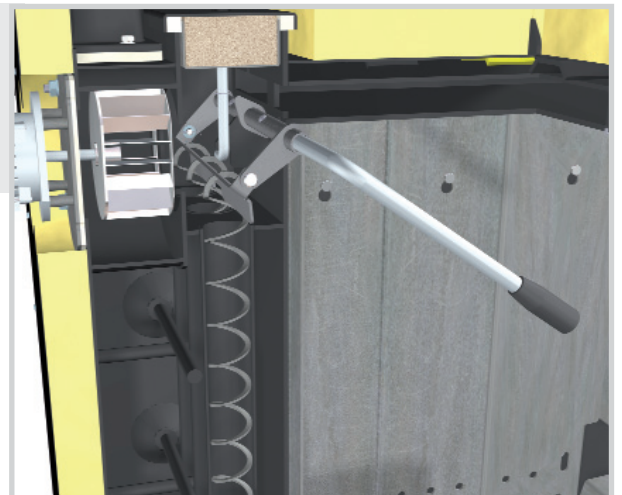

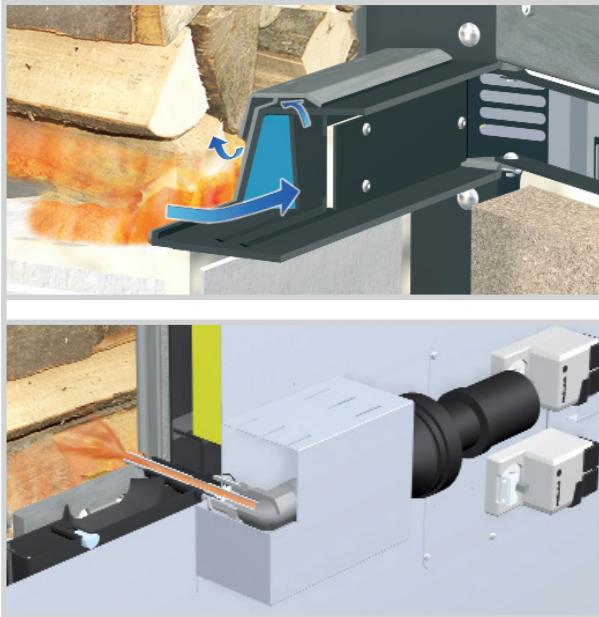

Feature: Unique automatic heat up

- Benefits:
- Load the boiler, light the fuel, close the door and that's it.
 - No smoke is produced in the boiler room.
 - Automatic ignition device (optional)

Now that's unique! Because of a special primary air duct, the heat-up chamber door on the S4 Turbo can be closed immediately after ignition, unlike traditional systems that supply air to wood fires.

If you like ease of operation, you will love the **automatic ignition device**. Heating with firewood can be so easy!

Feature: Special carbonisation gas extraction

- Benefits:
- No smoke escapes during reloading.
 - The boiler room stays clean

You can look forward to a clean boiler room! The special carbonisation gas extraction ensures that no smoke escapes, even during reloading. This ensures that the area where you operate the boiler remains pleasant.



Feature: Speed-regulated induced-draught fan

- Benefits:
- Maximum ease of use
 - Problem-free boiler start
 - Constant stabilisation of combustion

The S4 Turbo features an induced-draught fan as standard, optimising reliability. This means that the boiler can also be started without any difficulty when the chimney is cold. The speed-regulated induced-draught fan also stabilises combustion throughout, and adjusts the output to fit requirements.

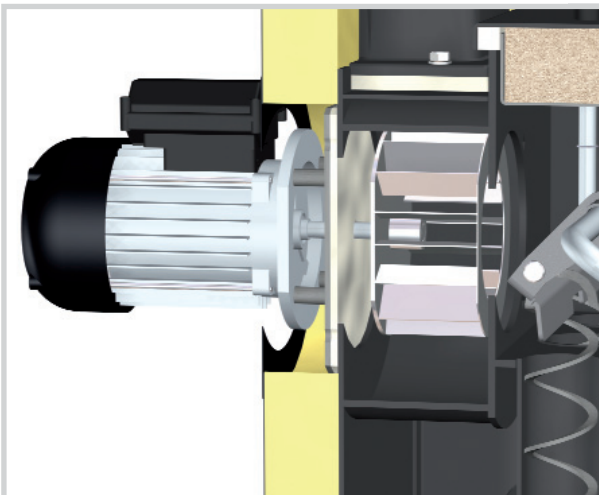

Systematic comfort

Feature: Lambdatronic S 3200 control system

- Benefits:
- Precise combustion control through serial lambda control and separate primary and secondary air control.
 - Large, clear control unit with adjustable viewing angle
 - Menu-based operation with online help
 - Boiler navigation from the living room



With the new S 3200 boiler control, Froling is stepping into the future. The control unit is optimised to fit requirements, and the individually adjustable viewing angle ensure that all operating statuses are clearly shown. The optimally organised menu structure makes it easy to operate. It is easy to select the important heating and hot water functions using the function keys.

The **Froling bus system** makes it possible to install extension modules at any location. For example, at the boiler, at the heat distributor, at the tank, in the living room or in the next house: the local controls can be installed wherever they are needed. Another positive feature is that the electrical cables are kept to a minimum.

The new **RBG 3200 room console** makes the system even easier to use. You can control the heating system easily from your living room. It is extremely easy to read off all the important values and status messages and to change settings at the push of a button.



Feature: Systems engineering for optimum energy consumption

- Benefits:
- Complete solution for all requirements
 - The components work together perfectly
 - Links in to solar energy

Froiling systems engineering enables efficient energy management. Up to 4 storage tanks, up to 8 hot water tanks and up to 18 heating circuits can influence heat management. You also benefit from the option of connecting other types of energy generation, such as solar panel systems.

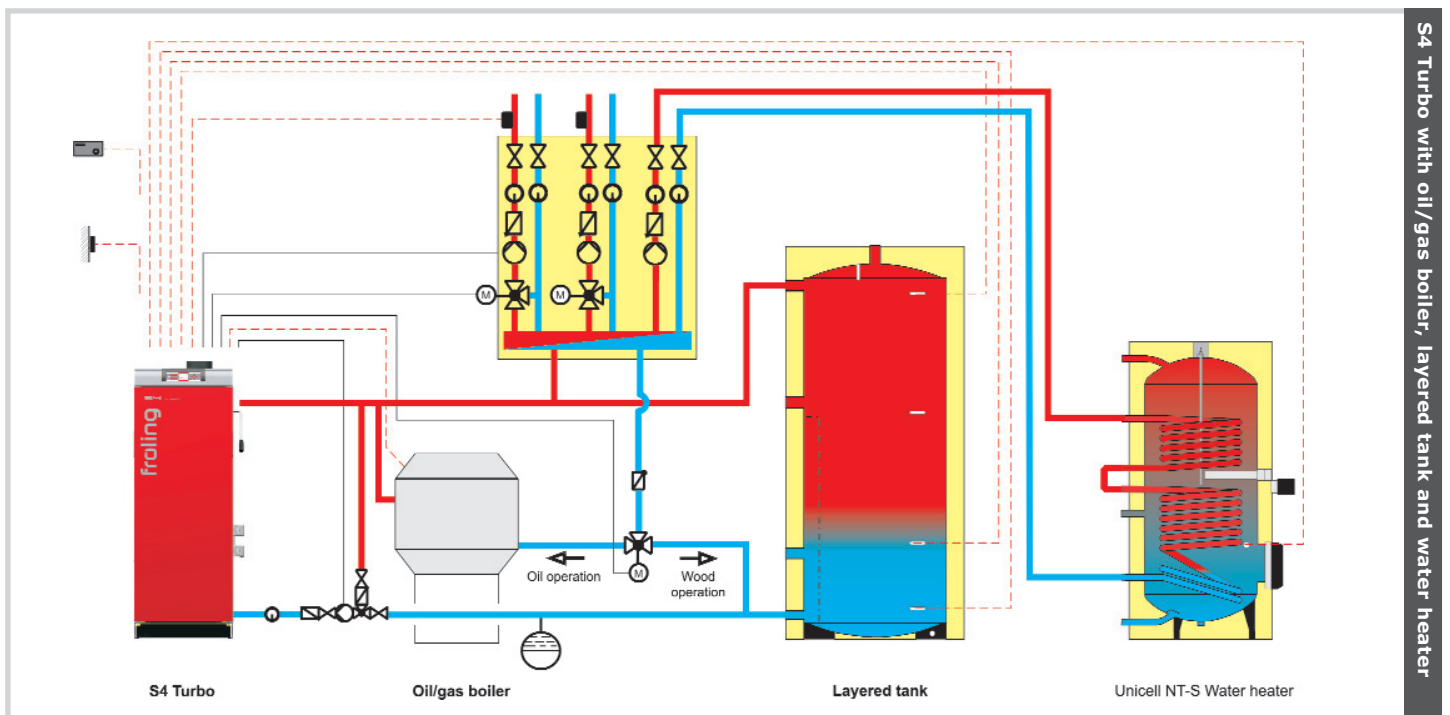
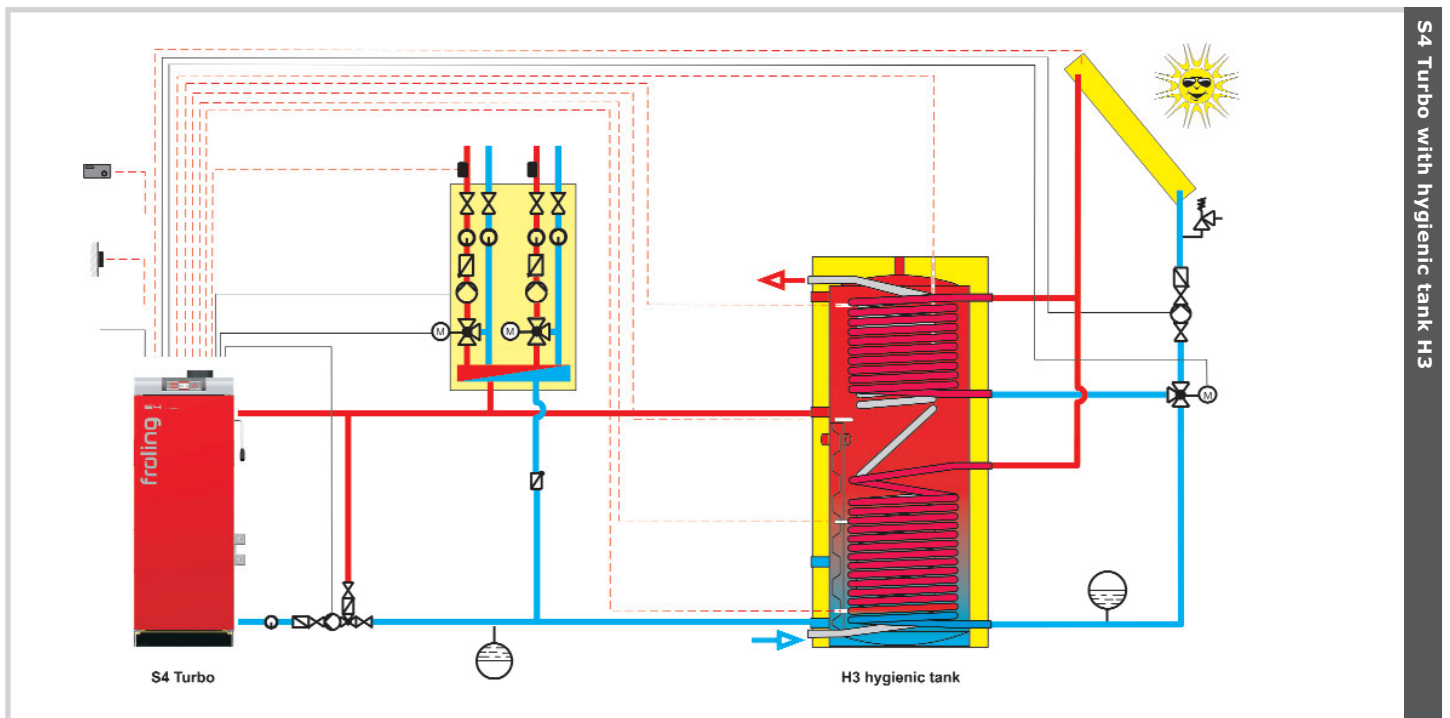

Technical Specifications

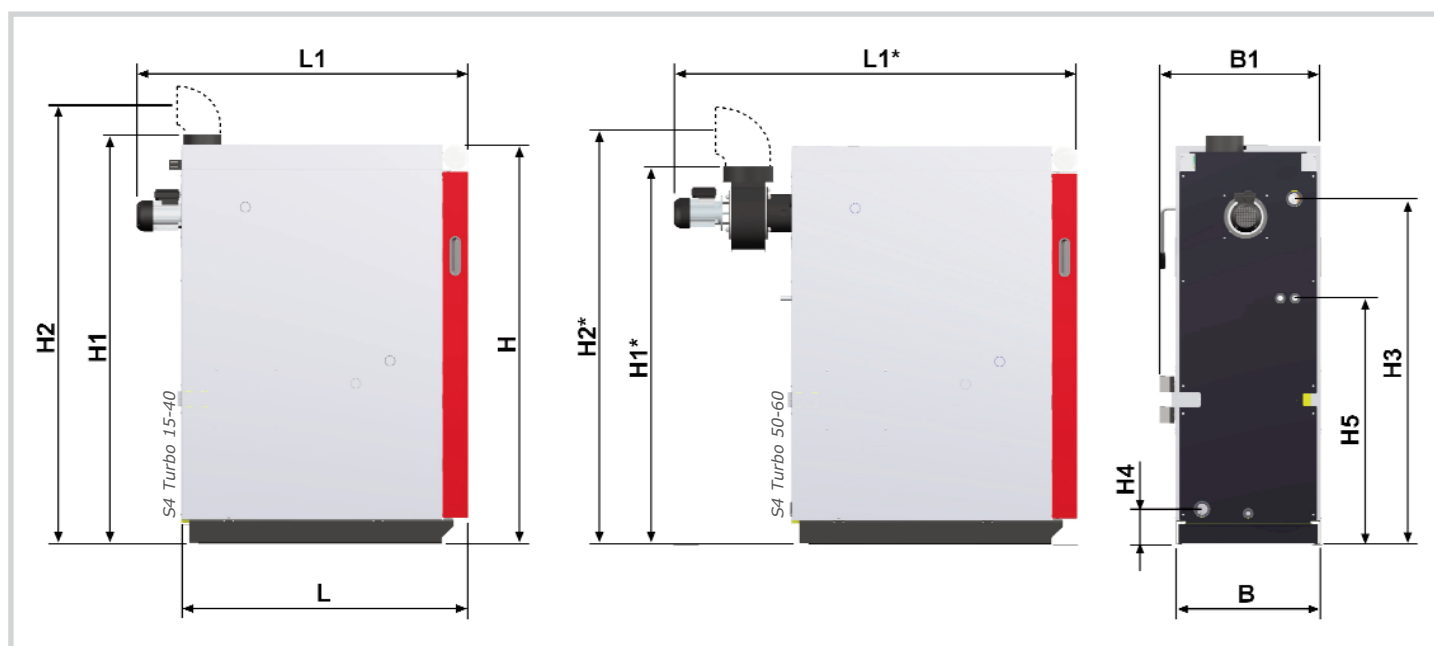

Dimensions - S4 Turbo		15	22	28	34	40	50	60
L	Length, boiler	1125	1125	1125	1215	1215	1215	1215
L1	Total length inc. induced draught fan	1300	1300	1300	1390	1390		
L1*	Total length inc. induced draught fan						1680	1680
B	Width, boiler	570	570	570	670	670	670	670
W1	Total width inc. actuators	635	635	635	735	735	735	735
H	Height, boiler	1565	1565	1565	1565	1565	1565	1565
H1	Total height, inc. flue gas pipe	1610	1610	1610	1610	1610		
H1*	Height, induced draught unit housing						1480	1480
H2	Height, flue pipe connection	1830	1830	1830	1830	1830		
H2*	Height, flue pipe connection						1700	1700
H3	Outfeed connection	1360	1360	1360	1360	1360	1360	1360
H4	Return feed connection	140	140	140	140	140	140	140
H5	Safety heat exchanger connection	970	970	970	970	970	960	960
	Flue pipe diameter	150	150	150	150	150	150	150

*) dimensions indicated only for S4 Turbo 50/60; all dimensions in mm

Technical specifications - S4 Turbo		15	22	28	34	40	50	60
Rated heat output	[kW]	15	22	28	34	40	50	60
Electrical power	[W]	105	105	125	110	110	180	180
Fuel loading chamber capacity	[L]	145	145	145	190	190	200	200
Fuel loading door (width/height)	[mm]	360 / 380	360 / 380	360 / 380	360 / 380	360 / 380	360 / 380	360 / 380
Water capacity	[L]	115	115	115	175	175	170	170
Boiler weight	[kg]	640	640	640	740	740	798	798

Further technical details on request.
We'll be happy to advise you.



**Heizkessel- und Behälterbau GesmbH
A-4710 Grieskirchen, Industriestr. 12**

Tel +43 (0) 7248 606 • Fax +43 (0) 7248 606-600
E-mail: info@froeling.com • Internet: www.froeling.com